

# Belt-type Capstans CA

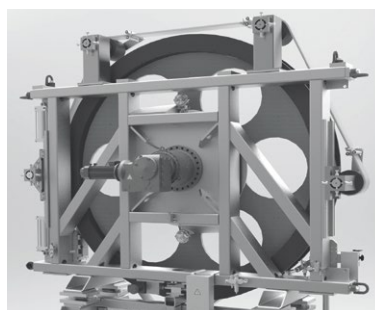
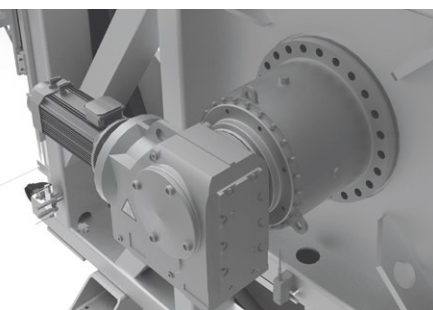
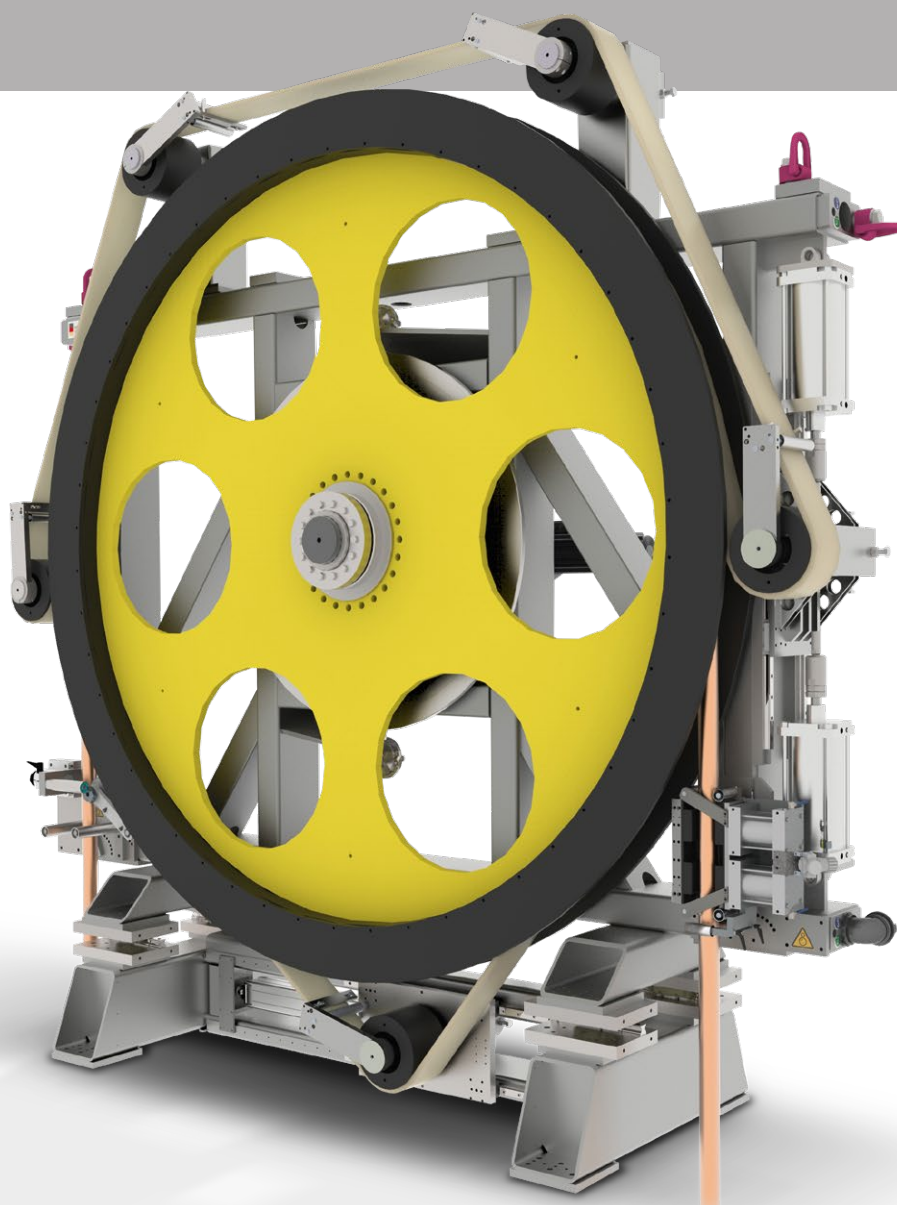

**TROESTER**

EXCELLENCE IN EXTRUSION.

# Belt-type Capstans CA

**Belt-type capstans CA are typically used in vertical continuous vulcanization lines as braking unit on top of the VCV tower.**

Depending on the application and available space, the capstans may also be used in medium voltage catenary lines (MV-CCV lines) where they will be installed as either braking and/or pulling unit.

With their strong design and long service life, these capstans guarantee reliable, efficient transmission of the tractive force to the cable. Constant speed is ensured by planetary gear without backlash. The belts are pneumatically tightened and are easy to replace. Belt-pressure can be regulated via control valve.

The capstans are designed to be adjusted to various conductor/cable diameters so that the material can be directed to the exact centre of the extruder head. All belt-type capstans are fitted with guide rollers at the in- and outlet.

Depending on the requirements, a measuring wheel with an impulse generator can be integrated to measure the line speed and/or lengths.

## Technical Data

		CA 1000	CA 1250	CA 1600	CA 2000	CA 2500	CA 3000	CA 3500	CA 4000	CA 4500
<b>Conductor/Cable Diameter</b>	mm	35	40	50	63	80	100	125	150	250
<b>max. Tractive/Brake Force</b>	N	10000	14000	22000	32000	38000	48000	60000	72000	80000
<b>max. Speed</b>	m/min	160	125	100	80	63	50	40	30	30
<b>Haul-off Pulley Diameter</b>	mm	1000	1250	1600	2000	2500	3000	3500	4000	4500



Belt-type Capstans CA

## Main Advantages of TROESTER Belt-type Capstans CA

- > Power transmission without backlash
- > High rotational accuracy
- > Precise guiding of the cable in the production process
- > Easy replacement of inner and outer belt
- > Strong Design for Extra High Voltage Cable production
- > High precision central planetary drive
- > Adjustable to cable center line by linear guidings
- > High safety standards

